

# **Model 8009 Resistivity Test Fixture**

---

## Instruction Manual

Contains Operating and Servicing Information

**KEITHLEY**

## WARRANTY

Keithley Instruments, Inc. warrants this product to be free from defects in material and workmanship for a period of 1 year from date of shipment.

Keithley Instruments, Inc. warrants the following items for 90 days from the date of shipment: probes, cables, rechargeable batteries, diskettes, and documentation.

During the warranty period, we will, at our option, either repair or replace any product that proves to be defective.

To exercise this warranty, write or call your local Keithley representative, or contact Keithley headquarters in Cleveland, Ohio. You will be given prompt assistance and return instructions. Send the product, transportation prepaid, to the indicated service facility. Repairs will be made and the product returned, transportation prepaid. Repaired or replaced products are warranted for the balance of the original warranty period, or at least 90 days.

## LIMITATION OF WARRANTY

This warranty does not apply to defects resulting from product modification without Keithley's express written consent, or misuse of any product or part. This warranty also does not apply to fuses, software, non-rechargeable batteries, damage from battery leakage, or problems arising from normal wear or failure to follow instructions.

THIS WARRANTY IS IN LIEU OF ALL OTHER WARRANTIES, EXPRESSED OR IMPLIED, INCLUDING ANY IMPLIED WARRANTY OF MERCHANTABILITY OR FITNESS FOR A PARTICULAR USE. THE REMEDIES PROVIDED HEREIN ARE BUYER'S SOLE AND EXCLUSIVE REMEDIES.

NEITHER KEITHLEY INSTRUMENTS, INC. NOR ANY OF ITS EMPLOYEES SHALL BE LIABLE FOR ANY DIRECT, INDIRECT, SPECIAL, INCIDENTAL OR CONSEQUENTIAL DAMAGES ARISING OUT OF THE USE OF ITS INSTRUMENTS AND SOFTWARE EVEN IF KEITHLEY INSTRUMENTS, INC., HAS BEEN ADVISED IN ADVANCE OF THE POSSIBILITY OF SUCH DAMAGES. SUCH EXCLUDED DAMAGES SHALL INCLUDE, BUT ARE NOT LIMITED TO: COSTS OF REMOVAL AND INSTALLATION, LOSSES SUSTAINED AS THE RESULT OF INJURY TO ANY PERSON, OR DAMAGE TO PROPERTY.



Keithley Instruments, Inc. • 28775 Aurora Road • Cleveland, OH 44139 • 440-248-0400 • Fax: 440-248-6168 • <http://www.keithley.com>

CHINA: Keithley Instruments China • Yuan Chen Xin Building, Room 705 • 12 Yumin Road, Dewai, Madian • Beijing 100029 • 8610-62022886 • Fax: 8610-62022892

FRANCE: Keithley Instruments SARL • BP 60 • 3 Allée des Garays • 91122 Palaiseau Cédex • 33-1-60-11-51-55 • Fax: 33-1-60-11-77-26

GERMANY: Keithley Instruments GmbH • Landsberger Strasse 65 • D-82110 Germering, Munich • 49-89-8493070 • Fax: 49-89-84930759

GREAT BRITAIN: Keithley Instruments, Ltd. • The Minster • 58 Portman Road • Reading, Berkshire, England RG3 1EA • 44-1189-596469 • Fax: 44-1189-575666

ITALY: Keithley Instruments SRL • Viale S. Gimignano 38 • 20146 Milano • 39-2-48303008 • Fax: 39-2-48302274

NETHERLANDS: Keithley Instruments BV • Avelingen West 49 • 4202 MS Gorinchem • 31-(0)183-635333 • Fax: 31-(0)183-630821

SWITZERLAND: Keithley Instruments SA • Kriesbachstrasse 4 • 8600 Dübendorf • 41-1-8219444 • Fax: 41-1-8203081

TAIWAN: Keithley Instruments Taiwan • 1FL., 85 Po Ai Street • Hsinchu, Taiwan • 886-3-572-9077 • Fax: 886-3-572-9031

# Model 8009 Resistivity Test Fixture Instruction Manual

©1995, Keithley Instruments, Inc.  
All rights reserved.  
Cleveland, Ohio, U.S.A.  
December 1996, Second Printing  
Document Number: 8009-901-01 Rev. B

# MANUAL PRINT HISTORY

The print history shown below lists the printing dates of all Revisions and Addenda created for this manual. The Revision Level letter increases alphabetically as the manual undergoes subsequent updates. Addenda, which are released between Revisions, contain important change information that the user should incorporate immediately into the manual. Addenda are numbered sequentially. When a new Revision is created, all Addenda associated with the previous Revision of the manual are incorporated into the new Revision of the manual. Each new Revision includes a revised copy of this print history page.

Revision A (Document Number 8009-901-01).....	January 1995
Revision B (Document Number 8009-901-01).....	December 1996

---

# Safety Precautions

The following safety precautions should be observed before using this product and any associated instrumentation. Although some instruments and accessories would normally be used with non-hazardous voltages, there are situations where hazardous conditions may be present.

This product is intended for use by qualified personnel who recognize shock hazards and are familiar with the safety precautions required to avoid possible injury. Read the operating information carefully before using the product.

The types of product users are:

**Responsible body** is the individual or group responsible for the use and maintenance of equipment, and for ensuring that operators are adequately trained.

**Operators** use the product for its intended function. They must be trained in electrical safety procedures and proper use of the instrument. They must be protected from electric shock and contact with hazardous live circuits.

**Maintenance personnel** perform routine procedures on the product to keep it operating, for example, setting the line voltage or replacing consumable materials. Maintenance procedures are described in the manual. The procedures explicitly state if the operator may perform them. Otherwise, they should be performed only by service personnel.

**Service personnel** are trained to work on live circuits, and perform safe installations and repairs of products. Only properly trained service personnel may perform installation and service procedures.

Exercise extreme caution when a shock hazard is present. Lethal voltage may be present on cable connector jacks or test fixtures. The American National Standards Institute (ANSI) states that a shock hazard exists when voltage levels greater than 30V RMS, 42.4V peak, or 60VDC are present. **A good safety practice is to expect that hazardous voltage is present in any unknown circuit before measuring.**

Users of this product must be protected from electric shock at all times. The responsible body must ensure that users are prevented access and/or insulated from every connection point. In some cases, connections must be exposed to potential human contact. Product users in these circumstances must be trained to protect themselves from the risk of electric shock. If the circuit is capable of operating at or above 1000 volts, **no conductive part of the circuit may be exposed.**

As described in the International Electrotechnical Commission (IEC) Standard IEC 664, digital multimeter measuring circuits (e.g., Keithley Models 175A, 199, 2000, 2001, 2002, and 2010) measuring circuits are Installation Category II. All other instruments' signal terminals are Installation Category I and must not be connected to mains.

---

Do not connect switching cards directly to unlimited power circuits. They are intended to be used with impedance limited sources. NEVER connect switching cards directly to AC mains. When connecting sources to switching cards, install protective devices to limit fault current and voltage to the card.

Before operating an instrument, make sure the line cord is connected to a properly grounded power receptacle. Inspect the connecting cables, test leads, and jumpers for possible wear, cracks, or breaks before each use.

For maximum safety, do not touch the product, test cables, or any other instruments while power is applied to the circuit under test. ALWAYS remove power from the entire test system and discharge any capacitors before: connecting or disconnecting cables or jumpers, installing or removing switching cards, or making internal changes, such as installing or removing jumpers.

Do not touch any object that could provide a current path to the common side of the circuit under test or power line (earth) ground. Always make measurements with dry hands while standing on a dry, insulated surface capable of withstanding the voltage being measured.

Do not exceed the maximum signal levels of the instruments and accessories, as defined in the specifications and operating information, and as shown on the instrument or test fixture panels, or switching card.

When fuses are used in a product, replace with same type and rating for continued protection against fire hazard.

Chassis connections must only be used as shield connections for measuring circuits, NOT as safety earth ground connections.

If you are using a test fixture, keep the lid closed while power is applied to the device under test. Safe operation requires the use of a lid interlock.

If a  screw is present, connect it to safety earth ground using the wire recommended in the user documentation.

The  symbol on an instrument indicates that the user should refer to the operating instructions located in the manual.

The  symbol on an instrument shows that it can source or measure 1000 volts or more, including the combined effect of normal and common mode voltages. Use standard safety precautions to avoid personal contact with these voltages.

The **WARNING** heading in a manual explains dangers that might result in personal injury or death. Always read the associated information very carefully before performing the indicated procedure.

The **CAUTION** heading in a manual explains hazards that could damage the instrument. Such damage may invalidate the warranty.

---

Instrumentation and accessories shall not be connected to humans.

Before performing any maintenance, disconnect the line cord and all test cables.

To maintain protection from electric shock and fire, replacement components in mains circuits, including the power transformer, test leads, and input jacks, must be purchased from Keithley Instruments. Standard fuses, with applicable national safety approvals, may be used if the rating and type are the same. Other components that are not safety related may be purchased from other suppliers as long as they are equivalent to the original component. (Note that selected parts should be purchased only through Keithley Instruments to maintain accuracy and functionality of the product.) If you are unsure about the applicability of a replacement component, call a Keithley Instruments office for information.

To clean the instrument, use a damp cloth or mild, water based cleaner. Clean the exterior of the instrument only. Do not apply cleaner directly to the instrument or allow liquids to enter or spill on the instrument.

# Specifications

## Operating Voltages:

1kV Peak Source (safety banana plugs supplied with 6517).

200V Peak Measure (triax, 3-lug).

200V Peak Common mode.

0.1A Peak Test Current.

1VA.

**Volume Resistivity Range:**  $10^3$  to  $10^{18}$  Ohm-cm.

**Surface Resistivity Range:**  $10^3$  to  $10^{17}$  Ohm.

**Center Electrode:** 50.8mm O.D.  $\pm$  0.05mm (2.0 in.  $\pm$  0.002 in.) conductive rubber pad.

**Electrode Concentricity:** Within 0.01 in. of center of ring electrode.

**Ring Electrode:** 57.2mm I.D.  $\pm$  0.05mm (2.25 in.  $\pm$  0.002 in.).

**Top Electrode:** 85.7mm O.D.  $\pm$  0.05mm, (3.375 in.  $\pm$  0.002 in.), 54mm diameter (2.125 in.) conductive rubber pad.

**Electrode Material:** Type #303 Stainless.

**Pad Durometer:** 70 Shore A.

**Pad Resistivity:** Volume =  $10\Omega$ /square max.

**Sample Size (Min.):** 63.5mm diameter (2.5 in.) (surface).

**Sample Size (Max.):** 101.6mm sq.  $\times$  3.2mm thick (4 in.  $\times$  0.125 in.).

**Interlock:** 4 pin for use with 6517.

## Test Force:

**Center Electrode:** 6 lbs. min.; 1.9 psi, 13.2 kPa.

10 lbs max.; 3.2 psi, 21.9 kPa.

**Ring Electrode:** 2 lbs. min.; 9.3 psi, 64.1 kPa.

23 lbs. max.; 107 psi, 737.6 kPa

(dependent upon sample thickness).

**Operating Temperature:**  $-30^{\circ}\text{C}$  to  $+80^{\circ}\text{C}$ .

**Operating Humidity:** 0% R.H. to 65% R.H. up to  $35^{\circ}\text{C}$ , linearly derate 3% R.H. per degree above  $35^{\circ}\text{C}$ .

**Dimensions:** 107.95mm high  $\times$  165.1mm wide  $\times$  139.7mm deep (4.25 in.  $\times$  6.5 in.  $\times$  5.5 in.).

**Weight:** 1.45kg (3.19 lbs.).

Specifications subject to change without notice.



# Table of Contents

---

## Section 1 — General Information

1.1	Introduction . . . . .	1
1.2	Supplied accessories . . . . .	1
1.3	Safety information. . . . .	2

## Section 2 — Operation

2.1	Overview . . . . .	5
2.2	ASTM standard . . . . .	8
2.3	Insulator sample mounting . . . . .	8
2.4	Connections. . . . .	9
2.5	Test voltage . . . . .	10
2.6	Current measurement range and compliance limit . . . . .	10
2.7	Electrification time . . . . .	11
2.8	Resistivity measurement procedure. . . . .	11

## Section 3 — Resistivity Calculations

3.1	Introduction . . . . .	13
3.2	Calculating Resistivity . . . . .	13
3.3	Resistivity nomographs. . . . .	16
3.4	Derivation of resistivity equations. . . . .	18

## Section 4 — Maintenance

4.1	Introduction . . . . .	23
4.2	Cleaning . . . . .	23
4.3	Replaceable parts. . . . .	23

# List of Illustrations

---

## Section 2 — Operation

Figure 2-1	Model 8009 resistivity test fixture . . . . .	6
Figure 2-2	Model 8009 schematic diagram . . . . .	7
Figure 2-3	Connecting the Model 6517 Electroemter/High Resistivity Meter to the Model 8009 test fixture . . . . .	9

## Section 3 — Derivation of Resistivity Equations

Figure 3-1	Basic measurement techniques . . . . .	15
Figure 3-2	Surface resistivity ( $\sigma$ ) nomograph . . . . .	16
Figure 3-3	Volume resistivity ( $\rho$ ) nomograph . . . . .	17
Figure 3-4	Electrode dimensions . . . . .	21

# List of Tables

---

## Section 4 — Maintenance

Table 4-1	Model 8009, replaceable parts .....	24
-----------	-------------------------------------	----

# 1

## General Information

---

### 1.1 Introduction

This packing list contains information on using the Model 8009 Resistivity Test Fixture. The Model 8009 allows volume resistivity measurements up to  $10^{18}$  ohm-cm or surface resistivity measurements up to  $10^{17}\Omega$ . The test fixture is designed using a three-lug triax connector that allows simple connection to a Keithley Model 6517 Electrometer.

#### Model 8009 features

All electrodes made from stainless steel for corrosion prevention.

Switchable volume/surface resistivity modes.

Operates with Keithley Model 6517 Electrometer/High Resistance Meter.

Safety interlock system and dual safety banana jacks for connection to 1kV source in Model 6517.

### 1.2 Supplied accessories

The following accessories are supplied with the Model 8009 test fixture:

- **Model 6517-ILC-3:** 1- meter, 4-pin interlock cable.
- **Model 7078-TRX-3:** A 3 ft. (0.9m) low noise triaxial cable that is terminated at both ends with 3-slot triaxial connectors. Used to connect the Model 8009 test fixture to the Model 6517 Electrometer.
- **8007-GND-3:** Safety ground wire with ground lug.

## 1.3 Safety information

### Safety symbols and terms

The following terms and symbols are found on the test equipment, or used in this packing list.

The  symbol on an instrument denotes the user should refer to the appropriate operating instructions.

The  symbol on an instrument denotes that 1000V or more may be present on the terminal(s). Use standard safety precautions to avoid personal contact with these voltages.

The **WARNING** heading indicates hazards that may cause personal injury or death. Always read over the information very carefully before performing the procedure.

The **CAUTION** heading explains hazards that could damage the instrument. Such damage may invalidate the warranty.

The ground screw  must be connected to a safety earth ground as explained in Section 2.

### Safety precautions

#### WARNING

**To avoid possible personal injury or death caused by electric shock, the following safety precautions must be observed when using the Model 8009 Resistivity Test Fixture.**

1. Resistivity tests typically use lethal voltage levels. Safe operation requires the proper use of the lid interlock.
2. Before use, connect the test fixture screw terminal to a safety earth ground using the Model 8007-GND-3 safety ground wire or #18 AWG (or larger) wire.
3. Do not exceed 1000V or 1A at the test fixture input triax connector.
4. Turn off the voltage source before connecting or disconnecting wires or cables in the test system.

5. Use the supplied triax cable and test leads to ensure that no conductive surfaces are exposed during the test.
6. After the test, set the voltage source to 0V and wait for the source to discharge before opening the lid of the test fixture.

#### NOTE

The Model 8009 Test Fixture includes a 10cm square, 1mm thick test sample. For maximum protection, the Model 8009 should always be stored with this sample between the electrodes.

# 2

## Operation

---

### 2.1 Overview

The basic method used to determine resistivity of an insulator sample is a two step process; first, a test voltage is applied to the sample and the subsequent current is measured. Then the test voltage value and measured current value are applied to the appropriate equation, and resistivity is calculated.

The Model 8009 Resistivity Test Fixture is shown in Figure 2-1. The top view shows the inside of the test fixture where the sample is mounted. The front view shows the pushbutton switch that is used to select the desired resistivity test. The side view shows the test fixture connectors.

The schematic diagram of the Model 8009 Resistivity Test Fixture is shown in Figure 2-2. Notice that external connection to the electrodes of the test fixture is accomplished through a 3-lug female triax connector. This connector will mate directly to a Keithley Model 6517 Electrometer/High Resistance Meter.

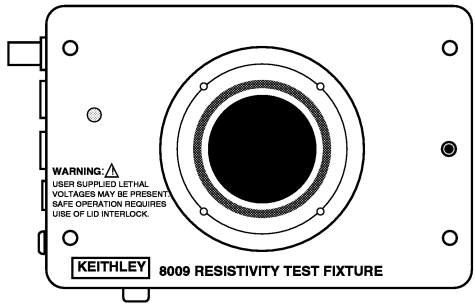

A. Top View (Sample Mounting)

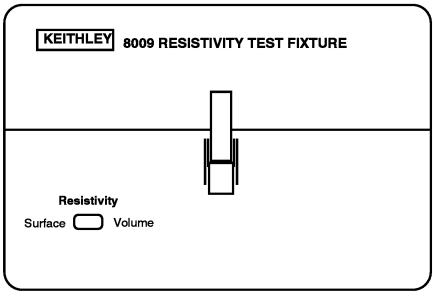

B. Front View (Resistivity Switch)

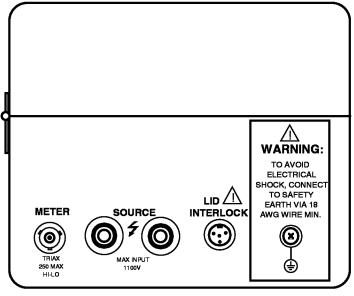

C. Side View (Connectors)

**Figure 2-1**  
 Model 8009 resistivity test fixture



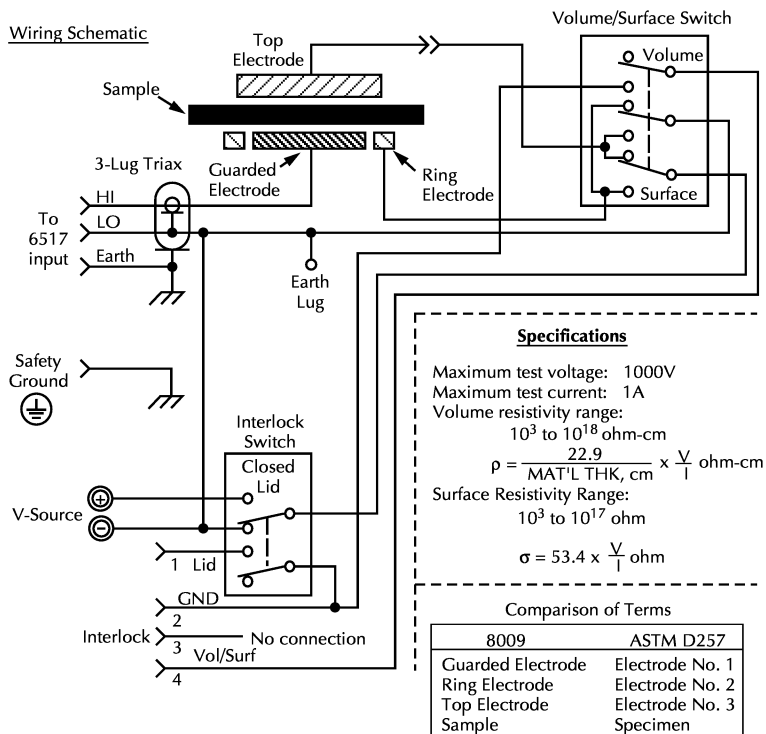

**Figure 2-2**  
 Model 8009 schematic diagram

## Model 6517 Electrometer/High Resistance Meter

The Model 8009 Resistivity Fixture is designed to fully support the enhanced resistivity measurement capability of the Model 6517 Electrometer/High Resistance Meter. The 6517 employs the ASTM D-257 measurement method, and displays measurements in resistance, surface resistivity, or volume resistivity. All the Model 8009 electrode constants are programmed into the Model 6517. A built-in high voltage source provides test voltages up to 1000 volts.

The Model 6517 offers special features for sophisticated, precise measurement of resistivity. The 6517 can automatically implement a “Bias-Measure” sequence in which the test voltage is applied for a programmed time to permit resistivity to reach equilibrium, after which the measurement can be made at some desired voltage. The Model 6517 can also measure and record temperature and relative

humidity using a type-K thermocouple (included with Model 6517), and the optional Model 6517-RH relative humidity probe.

The information presented in paragraphs 2.2 through 2.7 covers all aspects of theory of operation in detail. Paragraph 2.8 integrates the operating information together to provide a short, but comprehensive procedure to make resistivity measurements. Paragraph 3.3 provides resistivity nomographs that can be used to approximate resistivity.

## **2.2 ASTM standard**

Methods, recommendations and calculations used in this manual to make resistivity measurements are based on the following ASTM Standard:

American Society for Testing and Materials, Standard Methods of Test for Electrical Resistance of Insulation Materials, ASTM Designation D257

## **2.3 Insulator sample mounting**

The minimum and maximum sample sizes are listed in the specifications.

### **NOTE**

Do not handle the insulator sample with bare fingers. Body oil will provide a conductive path and may corrupt the measurement. The use of acetate rayon gloves is recommended. For best results, clean the sample surfaces with an alcohol and ether mixture or other suitable solvent.

Perform the following steps to mount the insulator sample in the Model 8009:

1. The top electrode in the Model 8009 is permanently attached to the top cover. A test sample is provided with the Model 8009 to protect the electrodes (this sample can be used for a functional check of the Model 8009). Remove the test sample. When finished, reinstall the test sample to protect the electrode surfaces from nicks and scratches.
2. Center the insulator sample between the top and bottom electrodes of the Model 8009. Make sure there are no conductive paths between the electrodes other than those through the sample.
3. Close the lid of the test fixture and secure the latch.

## 2.4 Connections

Refer to Figure 2-3 to connect the Model 6517 to the Model 8009 test fixture. The triax cable and the interlock cable are supplied with the Model 8009. Note that the ground link on the Model 6517 must be removed. Proper grounding will be performed by the Model 8009.

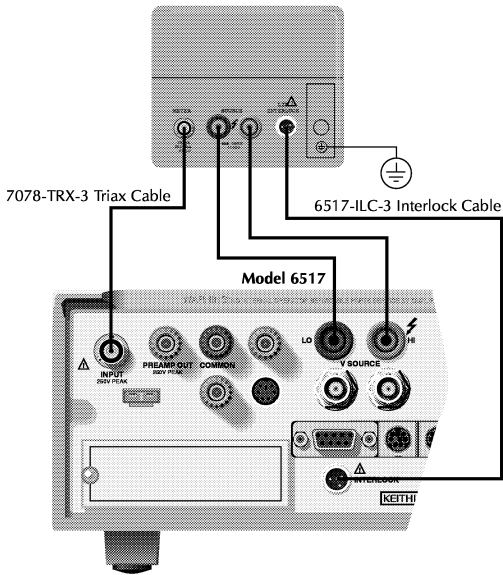

Warning: Connect  $\oplus$  of fixture to safety earth ground using safety ground wire (supplied with 8009 test fixture).

**Figure 2-3**  
*Connecting the Model 6517 Electrometer/High Resistivity Meter to the Model 8009 test fixture*

## Safety considerations

The earth ground screw terminal of the Model 8009 Resistivity Test Fixture must be connected to a known safety earth ground using the Model 8007-GND-3 ground wire, or #18 AWG or larger wire.

The use of hazardous voltage requires that interlock be used. The interlock circuit is activated when the Model 6517-ILC-3 interlock cable (supplied with the Model 6517) is connected as shown in Figure 2-3. Whenever the lid of the Model 8009 is open, the Model 6517 will go into standby, thus removing power from the test fixture.

### WARNING

To prevent electrical shock that could cause injury or death:

1. Put the Model 6517 voltage source in STANDBY before opening the lid of the Model 8009.
2. Make sure the interlock cable is connected as shown in Figure 2-3.
3. Make sure the earth ground screw on the Model 8009 is connected to a known safety earth ground using the Model 8007-GND-3, or #18 AWG or larger wire.

## 2.5 Test voltage

Typically specified test voltages to be applied to the insulator sample are 100V, 250V, 500V and 1000V. Higher test voltages are sometimes used, however the maximum test voltage that may be applied to the Model 8009 is 1000V. The most frequently used test voltages are 100V and 500V. The Keithley Model 6517 can provide test voltages up to 1000V.

## 2.6 Current measurement range and compliance limit

To make the most accurate resistivity measurement, the Model 6517 must be on the most sensitive (optimum) current measurement range. The simplest way to achieve this is by placing the Model 6517 in autorange.

In general, a current compliance limit is to protect the device under test (DUT). For virtually all resistivity tests, protecting the insulator sample from excessive current is not a concern.

If manual ranging must be used, you may have to experiment to determine the best measurement range and subsequent compliance limit. For detailed information on compliance and measurement range selection, refer to the Model 6517 instruction manual.

## 2.7 Electrification time

Electrification time is the total time that the specified voltage is applied to the insulator sample when the current measurement is taken. For example, for an electrification time of 60 seconds, the current measurement would be taken after the insulator sample was subjected to the applied voltage for 60 seconds. Keep in mind that special studies or experimentation may dictate a different electrification time.

Unless otherwise specified, an electrification of 60 seconds should be used.

## 2.8 Resistivity measurement procedure

The previously detailed operating information is integrated into the following procedure to make resistivity measurements.

### NOTE

The Model 6517 has a built-in test sequence for resistivity measurements. See the Model 6517 User's Manual for details.

### WARNING

**The following procedure uses hazardous voltage that could cause severe injury or death. Use extreme caution when the V-Source of the Model 6517 is in operate.**

### NOTE

To measure volume resistivity, the average thickness of the sample must be known. If thickness is not known, use calipers to obtain a precise measurement.

1. Mount the insulator sample in the Model 8009 test fixture. See paragraph 2.3 for details.

2. Close the lid of the test fixture, secure the latch, and set the RESISTIVITY switch for the desired test (SURFACE or VOLUME).
3. With the power off, connect the Model 6517 to the test fixture as shown in Figure 2-3. See paragraph 2.4 for details.

### WARNING

**To prevent electrical shock that could cause injury or death, make sure the interlock cable is properly connected and the Model 8009 earth ground screw is properly connected to a safety earth ground.**

4. With the V-Source in standby, configure the Model 6517 for the desired resistivity measurement:
  - The resistivity measurement type (volume or surface) is selected and configured from the CONFIGURE OHMS menu that is displayed by pressing CONFIG and then R.
  - Autorange and a high compliance limit will suffice for most tests (see paragraph 2.6). Typically, 500V is used as the test voltage for insulators (see paragraph 2.5).

### NOTE

Refer to the Model 6517 User's Manual for details on configuring the Model 6517 for resistivity measurements.

5. Place the V-Source in operate and after an appropriate electrification time, observe the resistivity reading on the display. Typically, an electrification period of 60 seconds is used (see paragraph 2.7).

### NOTE

If using an instrument that does not directly measure resistivity, you must calculate resistivity using the applied test voltage and measured current values. Resistivity calculations are provided in Section 3. If precision is not needed, use the nomographs to approximate resistivity.

6. Place the V-Source in standby.

# 3

## Resistivity Calculations

---

### 3.1 Introduction

For instruments that do not directly measure resistivity, this section provides the equations needed to calculate volume and surface resistivity using the applied test voltage and the measured current. If accuracy is not needed, nomographs can instead be used to approximate resistivity. This section also shows how to derive equations used to calculate resistivity.

### 3.2 Calculating resistivity

The following equations used to calculate volume and surface resistivity are based on the physical dimensions of the electrodes of the Model 8009. Paragraph 3.4, Derivation of resistivity equations, explains how these equations are derived.

**Volume Resistivity** — Volume resistivity is defined as the electrical resistance through a one-centimeter cube of insulating material and is expressed in ohm-centimeters. Likewise, the electrical resistance through a one-inch cube of insulating material is expressed as ohm-inches.

Volume resistivity ( $\rho_v$ ) is measured by applying a voltage potential across opposite sides of the insulator sample, measuring the resultant current through the sample (see Figure 3-1A), and then performing one of the following calculations:

Equation 1:  $\rho_v = \frac{22.9V}{t_c I}$  ohm-centimeter

or

Equation 2:  $\rho_v = \frac{3.55V}{t_i I}$  ohm-inches

where:  $\rho_v$  is the volume resistivity of the sample.

V is the applied test voltage.

$t_c$  is the average thickness of the sample in centimeters.

$t_i$  is the average thickness of the sample in inches.

I is the current reading.

#### NOTE

Equations 1 and 2 assume the effective area coefficient is zero. See paragraph 3.4 for details on deriving the volume resistivity equations.



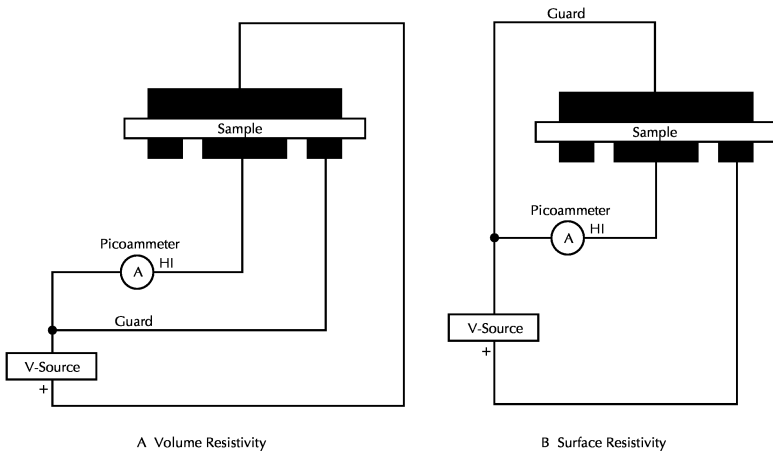

**Figure 3-1**  
*Basic measurement techniques*

**Surface Resistivity** — Surface resistivity is defined as the electrical resistance of the surface of an insulator material. It is measured from electrode to electrode along the surface of the insulator sample. Since surface length is fixed, the measurement is independent of the physical dimensions (i.e., thickness and diameter) of the insulator sample.

Surface resistivity ( $\rho_s$ ) is measured by applying a voltage potential across the surface of the insulator sample, measuring the resultant current (see Figure 3-1B), and then performing the following calculation:

Equation 3:  $\rho_s = \frac{53.4V}{I}$  ohms

where:  $\rho_s$  is the surface resistivity of the sample.  
 V is the applied voltage from the Electrometer.  
 I is the current reading from the Electrometer.

### 3.3 Resistivity nomographs

With test voltage and measured current (and sample thickness for volume resistivity) known, resistivity can be approximated by using the appropriate nomograph. Figure 3-2 shows the nomograph for surface resistivity, and Figure 3-3 shows the nomograph for volume resistivity.

**Surface Resistivity** — The surface resistivity nomograph (Figure 3-2) is made up of three scales: voltage, resistivity, and current. Perform the following steps to determine resistivity:

1. Plot the test voltage value on the voltage scale.
2. Plot the measure current value on the current scale.
3. Draw a straight line connecting the plotted voltage and current values.
4. Read the surface resistivity value (in ohms) from where the drawn line intersects the resistivity scale.

An example is shown in the graph. The dashed line connects a test voltage of 200V to a measured current of  $3 \times 10^{-10}$  amps (0.3nA). The dashed line intersects the resistivity scale at just under  $4 \times 10^{13} \Omega$  ( $3.56 \times 10^{13} \Omega$  by calculation).

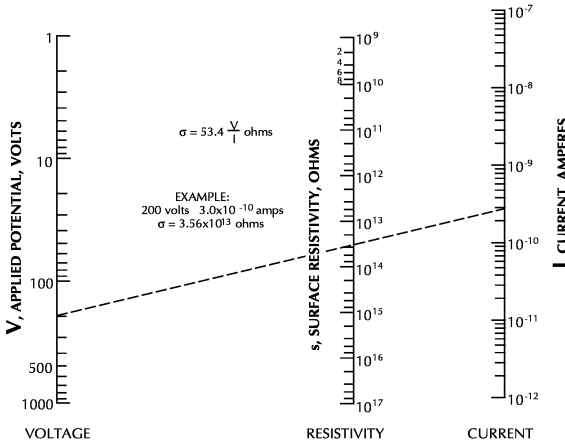
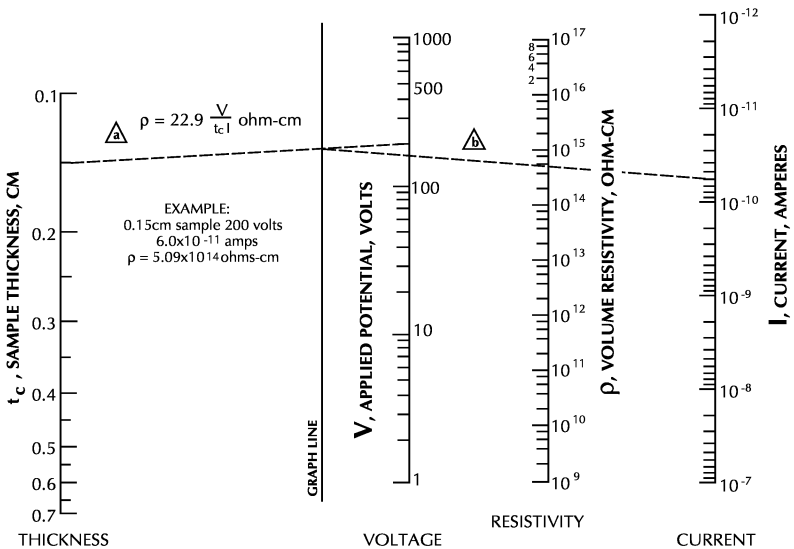

**Figure 3-2**  
Surface resistivity ( $\sigma$ ) nomograph

**Volume Resistivity** — The volume resistivity nomograph (Figure 3-3) is made up of four scales and a Graph Line. The four scales include; thickness (in cm) and current. Perform the following steps to determine volume resistivity:

1. Plot the average sample thickness (in cm) on the thickness scale.
2. Plot the test voltage value on the voltage scale.
3. Draw a straight line connecting the plotted thickness and voltage values. Note that this line will intersect the Graph Line.
4. Plot the measured current value on the current scale.
5. Draw a straight line from where the first line intersects the Graph Line to the plotted current value.
6. Read the volume resistivity value (in ohm-cm) from where the second line intersects the resistivity scale.

An example is shown on the graph. The first dashed line (a) connects a sample thickness of 0.15 cm to a test voltage of 200V. The second dashed line (b) connects the Graph Line intersection point to a measured current of  $6 \times 10^{-11}$  amps (60pA). The second dashed line (b) intersects the resistivity scale at approximately  $5 \times 10^{14} \Omega\text{-cm}$  ( $5.09 \times 10^{14} \Omega\text{-cm}$  by calculation).



**Figure 3-3**  
Volume resistivity ( $\rho$ ) nomograph

### 3.4 Derivation of resistivity equations

#### Volume resistivity

The ASTM standard states that volume resistivity ( $\rho_v$ ) shall be calculated as follows:

$$\text{Equation 4: } \rho_v = \frac{K_v R}{t}$$

where:  $R$  is the volume resistance in ohms.

$t$  is the average thickness of the sample.

$K_v$  is the effective area of the guarded electrode for the particular electrode arrangement employed.

For the Model 8009, which uses circular electrodes (see Figure 3-4),  $K_v$  is calculated as follows:

$$K_v = \pi \left( \frac{D\emptyset}{2} + \beta \frac{g}{2} \right)^2$$

where:  $D\emptyset$  is the effective diameter of the guarded electrode (5.40 cm or 2 $\frac{1}{8}$  in.).

$\beta$  is the effective area coefficient (typically zero).

$g$  is the distance between the guarded electrode and the ring electrode ( $\frac{1}{8}$  in.).

When  $\beta = \emptyset$ , the  $K_v$  calculation is simplified as follows:

$$K_v = \pi \frac{(D\emptyset)^2}{4}$$

Thus,

$$K_v = \pi \frac{(5.40)^2}{4} = 22.9 \text{ square centimeters}$$

or

$$K_v = \pi \frac{(2.125)^2}{4} = 3.55 \text{ square inches}$$

By using the calculated values for  $K_v$ , Equation 4 then becomes:

$$\rho_v = \frac{22.9}{t_c} R$$

or

$$\rho_v = \frac{3.55}{t_i} R$$

where:  $t_c$  is the average thickness of the sample in centimeters.  
 $t_i$  is the average thickness of the sample in inches.

Volume resistance (R) is derived by dividing the applied test voltage (V) by the subsequent measured current (I). By substituting R with V/I, the following equations that are used in Section 2 to calculate volume resistivity are realized:

$$\text{Equation 1: } \rho_v = \frac{22.9V}{t_c I} \text{ ohm-centimeter}$$

or

$$\text{Equation 2: } \rho_v = \frac{3.55V}{t_i I} \text{ ohm-inches}$$

### Surface resistivity

The ASTM standard states that surface resistivity ( $\rho_s$ ) shall be calculated as follows:

$$\text{Equation 5: } \rho_s = \frac{P}{g} R$$

where: R is the surface resistance in ohms.

g is 0.125 inches. This is the distance between the guarded electrode and the ring electrode (see Figure 3-4).

P is the effective perimeter of the guarded electrode for the particular electrode arrangement employed.

For the Model 8009, which uses circular electrodes, P is calculated as follows:

$$P = D_0 \pi$$

where  $D_0$ , which is the effective diameter of the guarded electrode (see Figure 3-4), is 2.125 inches. Thus,

$$P = 2.125\pi$$

By substituting the values for  $g$  and  $P$  into Equation 5, it then becomes:

$$\rho_s = \frac{2.125\pi}{0.125}R = 53.4R$$

Surface resistance ( $R$ ) is derived by dividing the applied test voltage ( $V$ ) by the subsequent measured current ( $I$ ). By substituting  $R$  with  $V/I$ , the following equation that is used in Section 2 to calculate surface resistivity is realized:

$$\rho_s = \frac{53.4V}{I} \text{ ohms}$$

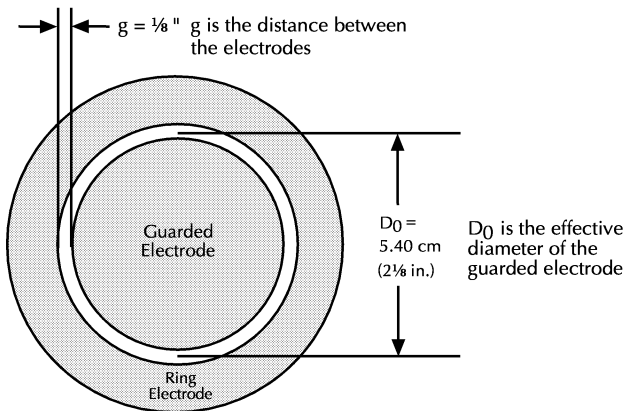

**Figure 3-4**  
*Electrode dimensions*

# 4

## Maintenance

---

### 4.1 Introduction

Normal maintenance for the Model 8009 simply consists of periodic cleaning of the electrodes and proper storage to keep the electrode surfaces from getting nicked and scratched. Also included in this section is a procedure to check out the operation of a test system, and a parts list.

### 4.2 Cleaning

The electrodes of the Model 8009 should be periodically cleaned with methanol or other suitable solvent. The connectors should also be kept clean to prevent leakage when measuring low level current.

When not in use, keep the supplied test sample installed between the electrodes. This will help prevent the surfaces of the electrodes from getting nicked and scratched.

### 4.3 Replaceable parts

Table 4-1 lists the replaceable parts that are available for the Model 8009. These parts can be obtained directly from Keithley Instruments, Inc. When ordering parts, be sure to indicate the Model number (8009), serial number, and the Keithley part number.

The unit can be returned for factory service, if desired. Call the Repair Department at 1-800-552-1115 for a Return Material Authorization (RMA) number. When returning the test fixture, write ATTENTION REPAIR DEPARTMENT on the shipping label, and be sure to advise as to the warranty status of the unit, as well as the type of service required.



**Figure 4-1**  
*Model 8009, replaceable parts list*

<b>Description</b>	<b>Keithley Part Number</b>
ASSY, 3LUG TRIAX CABLE	7078-308-3C
BOTTOM PLATE	8009-302A
BUSHING	14782G
CABLE ASSEMBLY	6517-330A
CENTER ELECTRODE	8009-305A
COMPRESSION SPRING	SP-7-1
COND RUBBER CENTER	8009-307A
COND RUBBER TOP	8009-308A
CONNECTOR TRIAX	CS-630
CONNECTOR, 4-PIN MALE	CS-458
CONN, BANANA JACK BLK	BJ-12-0
CONN, BANANA JACK RED	BJ-12-2
DRAW LATCH	FA-261
FOOT, BLACK MOLDED POLY	FE-10
GROUND STRAP	8009-318B
HANDLE	HH-29
INSULATOR TEFLON	11647
PLATE BASE	8008-305B
POGO PIN	CS-833
PUSHBUTTON	29465-9C
RING ELECTRODE	8009-304A
SAMPLE	8009-317A
SILICONE ADHESIVE	CE-17
SPACER, NYLON	15712B
SPACER PLATE	8009-309A
SPRING, LEAF	8009-310A
SWITCH	SW-493
SWITCH, DOOR INTERLOCK	SW-486
TEST BOX	8009-301B
TOP PLATE	8009-303A
TOP WEIGHTED ELECTRODE	8009-306A



# Service Form

Model No. \_\_\_\_\_ Serial No. \_\_\_\_\_ Date \_\_\_\_\_

Name and Telephone No. \_\_\_\_\_

Company \_\_\_\_\_

List all control settings, describe problem and check boxes that apply to problem.

\_\_\_\_\_

- |  |  |
|--|--|
| <input type="checkbox"/> Intermittent                  | <input type="checkbox"/> All ranges or functions are bad                 |
| <input type="checkbox"/> IEEE failure                  | <input type="checkbox"/> Particular range or function bad; specify _____ |
| <input type="checkbox"/> Front panel operational       | <input type="checkbox"/> Batteries and fuses are OK                      |
| <input type="checkbox"/> Analog output follows display | <input type="checkbox"/> Checked all cables                              |
| <input type="checkbox"/> Obvious problem on power-up   |  |

Display or output (check one)

- |                                   |  |
|-----------------------------------|--|
| <input type="checkbox"/> Drifts   | <input type="checkbox"/> Unable to zero              |
| <input type="checkbox"/> Unstable | <input type="checkbox"/> Will not read applied input |
| <input type="checkbox"/> Overload |  |

- |   |  |
|---|--|
| <input type="checkbox"/> Calibration only | <input type="checkbox"/> Certificate of calibration required |
| <input type="checkbox"/> Data required    |  |

(attach any additional sheets as necessary)

Show a block diagram of your measurement system including all instruments connected (whether power is turned on or not). Also, describe signal source.

Where is the measurement being performed? (factory, controlled laboratory, out-of-doors, etc.)

\_\_\_\_\_

What power line voltage is used? \_\_\_\_\_ Ambient temperature? \_\_\_\_\_ °F

Relative humidity? \_\_\_\_\_ Other? \_\_\_\_\_

Any additional information. (If special modifications have been made by the user, please describe.) \_\_\_\_\_

\_\_\_\_\_

Be sure to include your name and phone number on this service form.

**KEITHLEY**

**Keithley Instruments, Inc.**

28775 Aurora Road  
Cleveland, Ohio 44139

Printed in the U.S.A.